

# Buffer module CP-B 24/20.0, ultra-capacitor based Accessory for power supplies (e.g. switch mode power supplies CP range)

The CP-B 24/20.0 serves to ensure a short-term uninterrupted power supply system with a voltage of 24 V DC by buffering the load in case of power loss.

The buffer module features a new technology of storing energy by using ultra-capacitors which entirely obviate the need for maintenance and exempt deep discharge in comparison to batteries.

The energy storage can be expanded with additional extension modules for longer buffering times and is therefore utmost adaptable.



2CDC 271 003 S0010

## Characteristics

- Buffer module for supporting the supply system in case of mains failure
- Rated input voltage 24 V DC
- Rated output voltage 24 V DC
- Rated input current 20 A
- Rated output current 20 A
- Typical charging time < 135 s at 100 % load current
- Typical buffering time > 15 s at 100 % load current
- 2 relay contacts, normally open, 'INPUT OK' and 'BUFFER STATUS' status signal
- 1 relay contact, change-over, 'FAILURE' status signal
- 4 LEDs for indication of operational states
- 1 control signal input for specific switch off, 'SHUT-DOWN'
- Expandable with up to 2 extension modules CP-B EXT.2
- Maintenance free
- Temperature resistant
- No deep discharge

## Order data

### Buffer module

Type	Rated input voltage	Input voltage range	Rated output voltage	Rated output current	Order code
CP-B 24/20.0	24 V DC	23.4-27.4 V DC	24 V DC	20 A	1SVR 427 060 R2000

### Accessory

Type	Rated voltage	Voltage range	Order code
CP-B EXT.2	24 V DC	0-26.4 V DC	1SVR 427 065 R0000

## Functions

### Operating controls and terminals

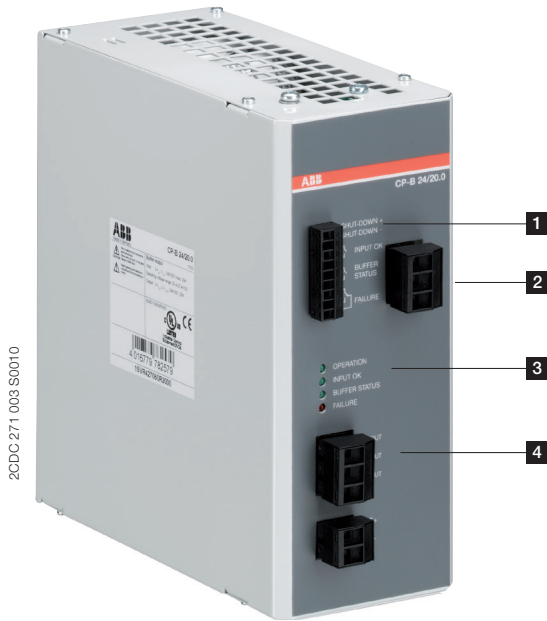

#### 1 Signalling

SHUT-DOWN+, SHUT-DOWN-: Input signal terminals

INPUT OK, BUFFER STATUS, FAILURE:

Signalling contact – terminals

#### 2 Input terminals

L+<sub>IN</sub>, L-<sub>IN</sub>, L-<sub>IN</sub>: Input voltage terminals

#### 3 Indication of operational states

OPERATION: Buffer module in operation (standby or buffering)

INPUT OK: Input voltage applied

BUFFER STATUS, FAILURE: details see table 'LEDs, status information and fault messages' on page 4

#### 4 Output terminals

L+<sub>OUT</sub>, L-<sub>OUT</sub>, L-<sub>OUT</sub>: Output voltage terminals

EXT+, EXT-: Connection terminals for extension module

### Application

In most areas of energy management and automation technology power supply systems have to be highly reliable. Often batteries are used for supporting the supply system in case of mains failures. Batteries have limited lifetimes depending on environmental parameters and, therefore, have to be maintained regularly, which causes efforts and costs.

Using the latest ultra-capacitor technology, ABB offers an innovative and completely maintenance-free new product for buffering the 24 V DC supply at 20 A in case of interrupted mains on the primary side of the power supply.

The CP-B 24/20.0 buffer module provides an ultra-capacitor buffered energy storage for power supply units. It ensures a short-term uninterrupted power supply system. In case of power loss, the energy stored in the capacitors guarantees that the load is continually provided, depending on the load current, up to several hundred seconds.

### Additional extensibility

In order to ensure a longer uninterrupted power supply, the energy storage can be easily extended with up to 2 additional extension modules.

### Example of application

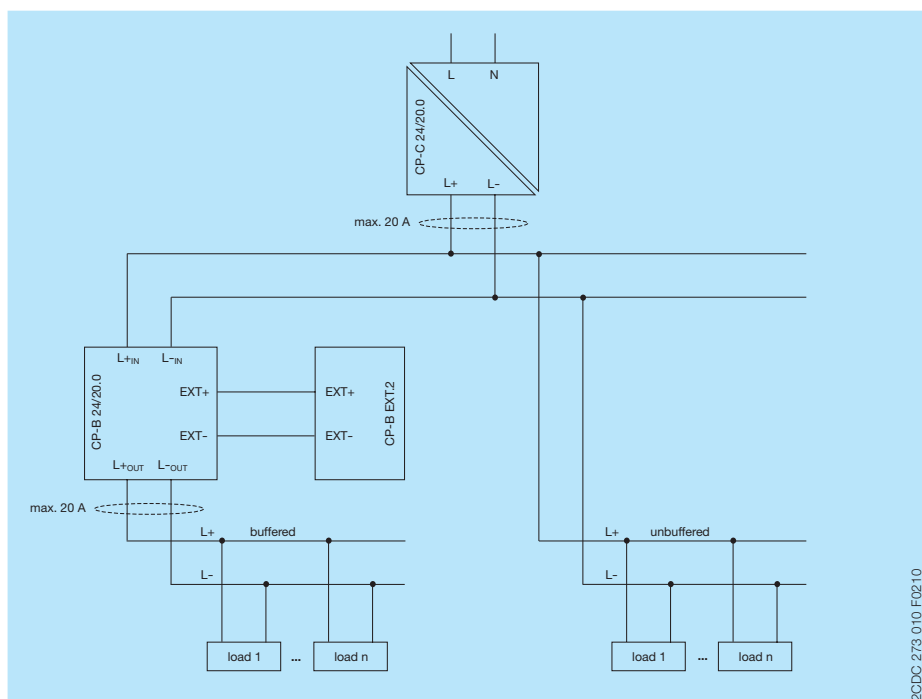

## Operating mode

A power supply has to be connected to the buffer module's terminals L<sub>+IN</sub> and L<sub>-IN</sub>. Once the input voltage has been applied, the buffer module starts loading its ultra-capacitors. Having achieved an energy level greater than 80% of the nominal capacitance, the LED 'BUFFER STATUS' glows. Regardless of the energy level, the buffer module provides the according output voltage after having applied the minimum charging potential on the input side for about 2 s.

In case of interrupted mains on the primary side of the power supply the buffer module guarantees that the load connected to terminals L<sub>+OUT</sub> and L<sub>-OUT</sub> is continually provided. In order to display the interrupted supply on the primary side the LED 'INPUT OK' turns off while the capacitors are being discharged. When the energy level drops below 30% of the nominal capacitance, the LED 'BUFFER STATUS' turns off.

The LED 'FAILURE' indicates faults due to overvoltage at the internal capacitors as well as overcurrent at the output.

The messaging relays 'INPUT OK', 'BUFFER OK' and 'FAILURE' are coupled with the correspondent LED which glows while the according relay is energized.

## Important operating features

To trigger a safe shut-down of connected loads, a 24 V DC control signal can be applied to the terminals labelled 'SHUT-DOWN+' and 'SHUT-DOWN-'. This effects that buffered loads can be switched off in a defined state. Furthermore the shut-down can be used if a specific energy level of the capacitors has to be conserved.

Its advantage is that a subsequent charging of the capacitors can be shortened.

For applications where higher currents are needed for a short time (e.g. energization of contactors), the buffer module is able to provide double of its rated output current for 1.5 s. To use this feature, completely charged capacitors are required.

## Decommissioning

To put the buffer module out of operation, the power supply has to be turned off. Subsequently the buffer module continues to supply the load until the capacitors are discharged.

In order to circumvent the subsequent buffering operation and the discharge of the capacitors, the module can be directly switched off by activating the shut-down without buffering. All LEDs turn off immediately.

## Functional interaction of power supply and buffer module in charging operation

The buffer module's ultra-capacitors require a minimum charging potential, which has to be provided by the power supply. The minimum charging potential is necessary to charge the capacitors or to preserve the energy level in case of fully loaded capacitors. The charging process and the charging time of the buffer module depend on the input and the load current. Having buffered and unbuffered loads connected to the power supply result in a split up of its provided current into parallel divided circuits (see 'Example of application' on page 2).

In order to use the maximum available current provided by the power supply, the buffer module acts as a variable load. The module decreases its load, if the rated input current of the buffer module would cause the power supply to cut the output voltage down (load limiting function) or to perform a slow lowering of the output voltage, resulting in an input voltage lower than the specified minimum charging potential. In this way the buffer module ascertains the fastest possible charging process according to the power supply used.

*Note:* It is highly recommended that loads which do not need an uninterrupted supply are connected directly, in parallel to all buffered loads, with the power supply. Buffering such loads would only reduce the buffering time which is load dependent. Therefore loads should be selected as small as necessary in order to achieve high buffering times.

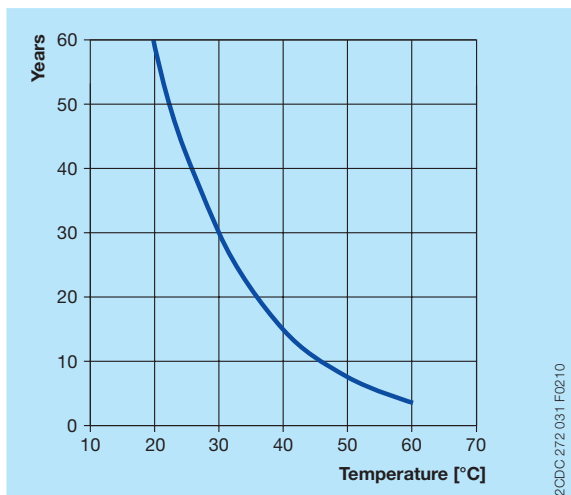

Capacitor's life span over temperature

*Note:* The capacitor's life span depends on the temperature exposed to as shown in the figure below as well as on the load current. The end of the life span is reached, when its capacitance drops below 70% of its nominal capacitance. Using the buffer module continuously at its specified maximum applicable temperature, the expected product lifetime is approximately 5 years.

## Indication of operational states

### LEDs, status information and fault messages

Operating state	INPUT OK LED green	OPERATION LED green	BUFFER STATUS LED green	FAILURE LED red
Input voltage applied			--	--
Device in operation (input voltage applied or internally supplied by using energy stored in capacitors)	--		--	--
Charging process (energy stored in capacitors > 30 and < 80 % )			--	--
Energy stored in capacitors > 80 % (while charging)				--
Energy stored in capacitors < 30 % (while discharging)	OFF		OFF	
Capacitors discharged (load no longer supplied, only internal supply is maintained)	OFF		--	
Overvoltage at internal capacitors, overcurrent at output, overvoltage at input terminal	--		--	
Capacitors discharged or shut-down activated	OFF	OFF	OFF	OFF

-- = not relevant

## Installation

The device must be installed by qualified persons only and in accordance with the specific national regulations (e.g. VDE, etc.). The CP-B 24/20.0 is a chassis-mounted unit. It is maintenance-free and does not contain any integral setting elements and should therefore not be opened.

If the buffer module is built into systems needing overvoltages for testing (e.g. EN 60204-1/ VDE0113 part1 19.4 voltage control), the module must be disconnected during the test. (Original text EN 60204-1: components, which are not dimensioned for the testing voltage must be separated during the testing.)

*Note:* The device is completely maintenance free. The enclosure is sealed.



**DANGER!**

**Components with high stored energy**

**Danger to be electrocuted!**

- ▶ Disconnect the system from the supply network and protect against switching on before any installation, maintenance or modification work.
- ▶ Discharge the buffer module completely.
- ▶ Do not introduce any objects into the unit and do not open the unit.
- ▶ Ensure that the service personnel is protected against inadvertent contact with parts carrying energy.

## Mounting position

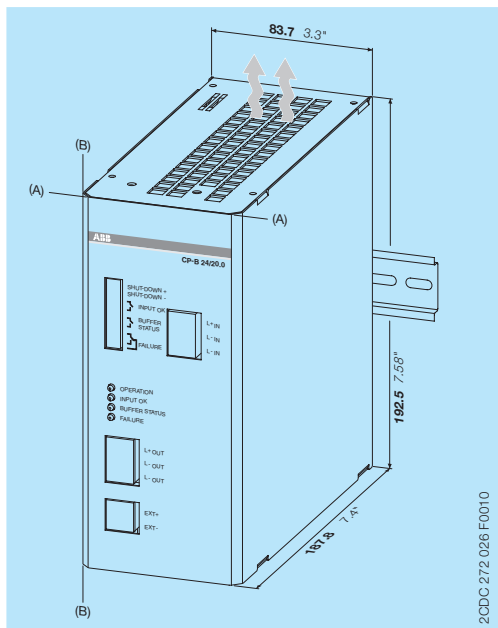

The device has to be mounted horizontally with the input terminals on the bottom. In order to ensure a sufficient convection, the minimum distance to the other modules must be not less than 80 mm (3.15 in) in vertical direction. Minimum distance in horizontal direction is not necessary.

## Electrical connection

The installation must be executed according to EN 60950 and possible applicable local standards. The input side is protected by an internal input fuse.

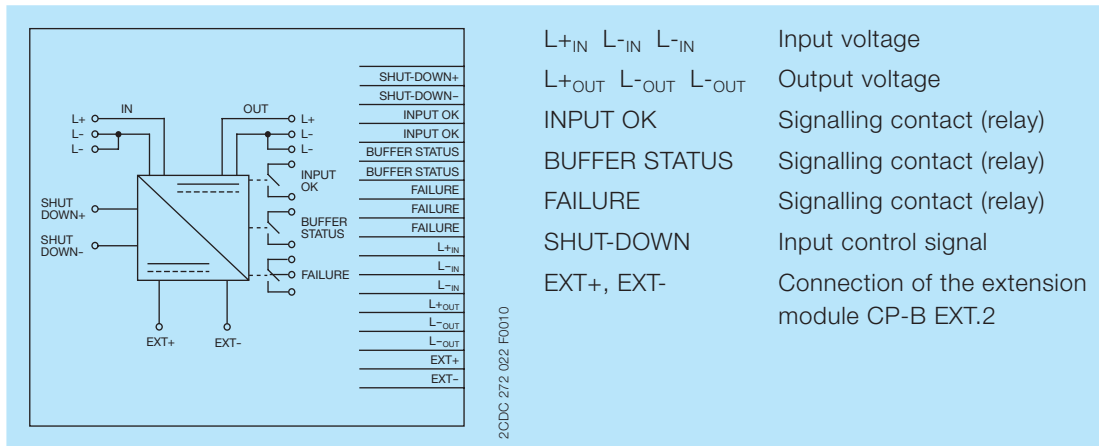

Connection diagram

1. Connect the load to be buffered to the output terminals L+<sub>OUT</sub> and L-<sub>OUT</sub>.
2. Additional extension modules (CP-B EXT.2) are connected to the terminals EXT+ and EXT-.
3. The signalling contact 'INPUT OK' can be used for external status analysis.

In case of overload, the output current comprises the maximum current of the buffer module as well as the current of the power supply unit. The overload protection has to be realized externally.

Rate the lines for the maximum output current or provide separate fuse protection. It is recommended to choose the wire size as large as possible in order to minimize voltage drops. Observe the polarity. The device is overload and open-circuit proof.

## Operation



**DANGER!**

**High current**

**Risk of electric arcs and electric shocks!**

- ▶ Do not modify the installation (primary and secondary side).
- ▶ Intended use.



**CAUTION!**

**Enclosure can become very hot depending on the operation conditions**

**Risk of burns!**

- ▶ In order to ensure sufficient air-cooling the distance to other devices has to be considered.

Before start of operation the following must be ensured:

1. Connect electrical lines according to the specific national regulations for class of protection III.
2. Power supply cables and unit must be sufficiently fused.
3. A disconnection device has to be provided for the power supply to disengage unit and supply cables from supply mains if required.
4. Rate the output lines for the output current of the buffer module and connect them with the correct polarity.

If the buffer module is entirely charged and works in the standby mode, there is no heating of the module. From the thermal point of view this can be compared with a switched-off device.

The device is intended for use as a buffer module. Any other usage is not supported by the manufacturer. Other usage, improper installation or operation may impair safety and cause operational difficulties or destruction of the unit.

## Service

The internal fuse is not user-replaceable. If the internal fuse blows, most probably the device is defective. In this case, an examination of the buffer module by the manufacturer is necessary.

## Technical data

Data at  $T_a = 25\text{ °C}$  and rated values, unless otherwise indicated

### Input circuits

Supply circuit		$L+_{IN}$ $L-_{IN}$
Rated input voltage $U_{in}$		24 V DC
Input voltage range		23.4-29 V DC
Minimum charging potential		23.4 V DC
Rated input current		20 A DC
Inrush current limiting		35 A / 2 ms
Transient overvoltage protection		varistor / suppressor diode
Internal input fuse (apparatus protection, not accessible)		30 A (FK2)
Internal fuse capacitors circuit (not accessible)		30 A (FK2)
Kind of input	SHUT-DOWN	control input
	rated voltage	24 V DC
	voltage range	6-45 V DC

### Indication of operational states

		details see table 'LEDs, status information and fault messages' on page 4
Input voltage	INPUT OK	LED green
Internal system voltage	OPERATION	LED green
Energy storage level	BUFFER STATUS	LED green
Fault status	FAILURE	LED red

### Output circuits

		$L+_{OUT}$ $L-_{OUT}$ $L-_{OUT}$
Rated output power		480 W
Rated output voltage $U_{out}$		24 V DC
Output voltage (buffer mode)		23.2 V DC
Tolerance of the output voltage		+2...-10 %
Rated output current $I_r$	$T_a \leq 60\text{ °C}$	20 A DC
Peak output current (fully loaded capacitors required)	$T_a \leq 60\text{ °C}$	40 A DC (min. 1.5 s)
Short-circuit protection (via internal 30 A fuse and external 25 A fuse)		no continuous short-circuit stability
Internal output fuse (not accessible)		30 A (FK2)
Required external fuse		25 A slow acting
Power failure buffering time		load-dependent, min. 15 s at 100% load
Overload protection		thermal protection
Kind of output	INPUT OK	n/o contact
	BUFFER STATUS	n/o contact
	FAILURE	c/o contact
Contact material		Ag + Au-clad
Minimum switching voltage / Minimum switching current		5 V DC / 1 mA
Maximum switching voltage / Maximum switching current		50 V AC / 1 A, 30 V DC / 0.5 A
Mechanical lifetime		$5 \times 10^6$ switching cycles
Electrical lifetime		$0.1 \times 10^6$ switching cycles
Maximum fuse rating to achieve short-circuit protection	n/o or n/c contact	1.0 A AC / 0.5 A DC

## General data

MTBF		available on request
Maximum internal power consumption		40 W
Power consumption with unloaded output		1.6 W
Energy storage (min.)		8000 Ws
Typical charging time at load current	100 %	135 s
	0 %	62 s
Typical buffering time at load current <sup>1)</sup>	100 %	15 s
	50 %	30 s
	25 %	60 s
	10 %	150 s
Efficiency		greater than 90 %
Duty time		100 %
Dimensions		see "Dimensional drawings"
Weight	net	2.2 kg (4.85 lb)
Material of enclosure	cover	steel sheet powdered
	enclosure shell	steel sheet powdered
Mounting		DIN rail (IEC/EN 60715), snap-on mounting
Mounting position		horizontal
Minimum distance to other units	horizontal	not necessary
	vertical	80 mm (3.15 in)
Pollution degree		2
Degree of protection	enclosure	IP20
	terminal	IP20
Protection class (IEC/EN 61140)		III SELV / PELV (condition: power supply fulfills class III)

$$1) \text{ buffering time } \approx \frac{\text{energy storage} \times 0.9}{\text{load current} \times 23.2 \text{ V}}$$

## Electrical connection (pluggable screw type terminals)

Input circuit, output circuit		
Connecting capacity	fine-strand with wire end ferrule with(out) plastic sleeve	0.25-4.0 mm <sup>2</sup>
	fine-strand without wire end ferrule	0.2-4.0 mm <sup>2</sup>
	rigid	0.2-4.0 mm <sup>2</sup>
	AWG	24-10
Stripping length		7.0 mm (0.28 in)
Tightening torque	max.	0.6 Nm (5.31 lb.in)
Recommended screw driver		Ø 3.5 mm (0.14 in)
Signalling circuit		
Connecting capacity	fine-strand with wire end ferrule without plastic sleeve	0.25-1.5 mm <sup>2</sup>
	fine-strand with wire end ferrule with plastic sleeve	0.25-0.5 mm <sup>2</sup>
	fine-strand without wire end ferrule	0.14-1.5 mm <sup>2</sup>
	rigid	0.14-1.5 mm <sup>2</sup>
	AWG	28-16
Stripping length		7.0 mm (0.28 in)
Tightening torque	max.	0.25 Nm (2.21 lb.in)
Recommended screw driver		Ø 2.5 mm (0.10 in)

## Environmental data

Ambient temperature	operation	-40...+60 °C (-40...+140 °F)
	storage	-40...+60 °C (-40...+140 °F)
Vibration, sinusoidal	based on IEC/EN 60068-2-6	1.6 mm, 2-17.62 Hz; 2 g, 17.62-500 Hz, 20 cycles
Shock, half-sine	based on IEC/EN 60068-2-27	15 g, 11 ms, 3 axes, 6 faces, 3 times for each face

## Standards / Directives

Standards	EN 50178, IEC/EN 60950-1, IEC/EN 62040-2
Low Voltage Directive	2014/35/EU
EMC Directive	2014/30/EU
RoHS Directive	2011/65/EU

## Electromagnetic compatibility

Interference immunity to		IEC/EN 61000-6-2
electrostatic discharge	IEC/EN 61000-4-2	Level 3, 6 kV / 8 kV
radiated, radio-frequency, electromagnetic field	IEC/EN 61000-4-3	Level 3, 10 V/m (27-1000 MHz) / Level 2, 3 V/m (1400-2700 MHz)
electrical fast transient / burst	IEC/EN 61000-4-4	Level 3, 2(1) kV / 5 kHz
surge	IEC/EN 61000-4-5	Level 1, 0.5 kV
conducted disturbances, induced by radio-frequency fields	IEC/EN 61000-4-6	Level 3, 10 V (150 kHz-80 MHz)
voltage dips, short interruptions and voltage variations	IEC/EN 61000-4-11	buffered by ultra-capacitors
Interference emission		EN 61000-6-4
high-frequency radiated	DIN EN 55011	B/C1
high-frequency conducted	DIN EN 55011	B/C1

## Technical diagrams

### Temperature behavior

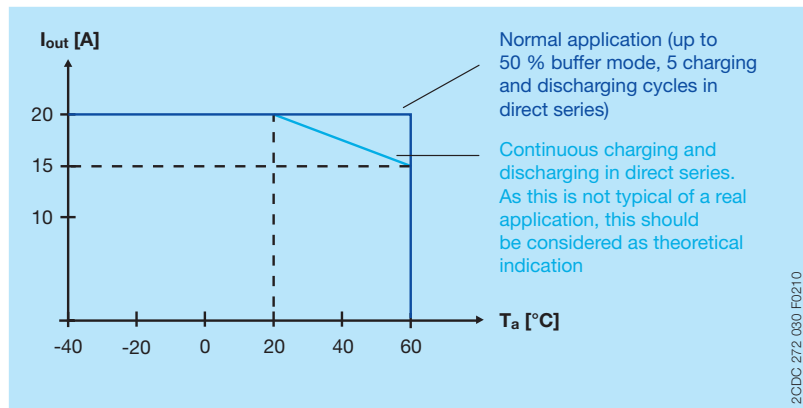

Characteristic curve of the temperature at rated load



**Dimensions**

in **mm** and inches

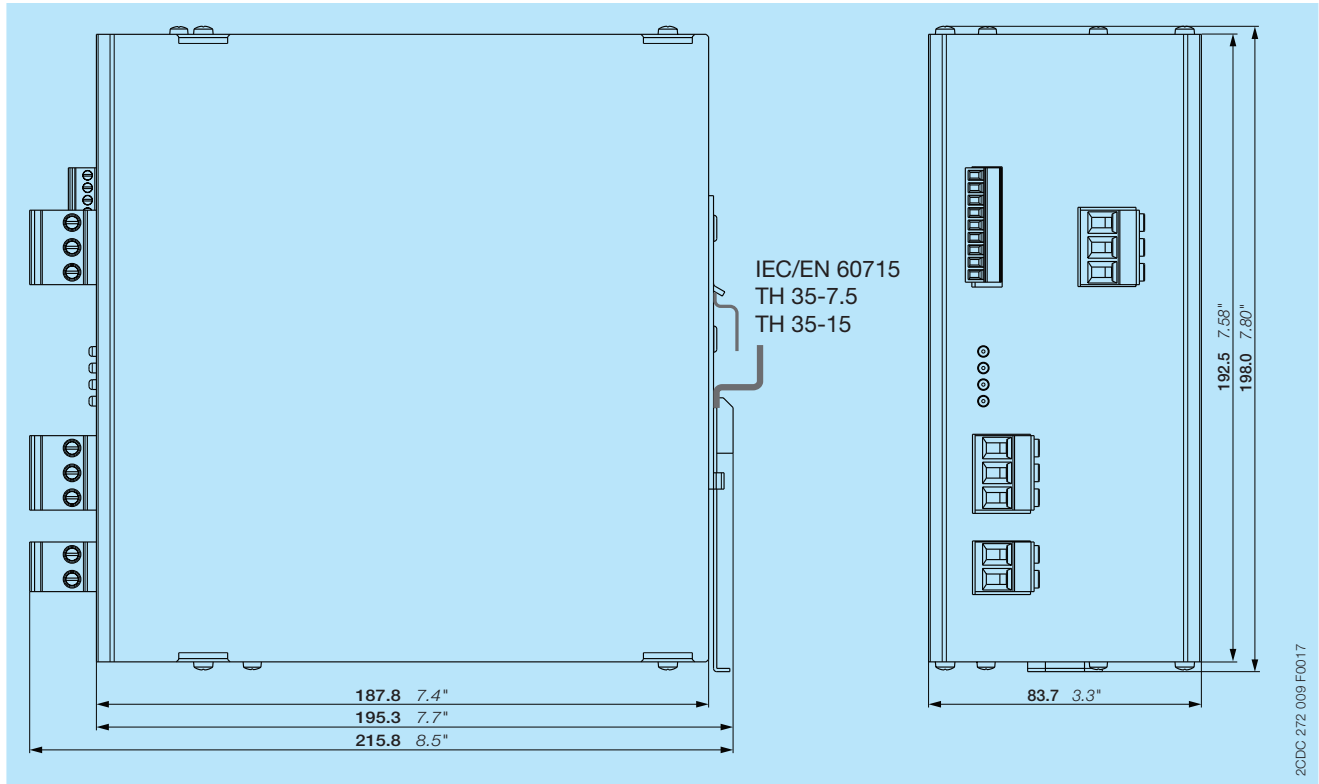

CP-B 24/20.0 (pluggable screw type terminals included in delivery)

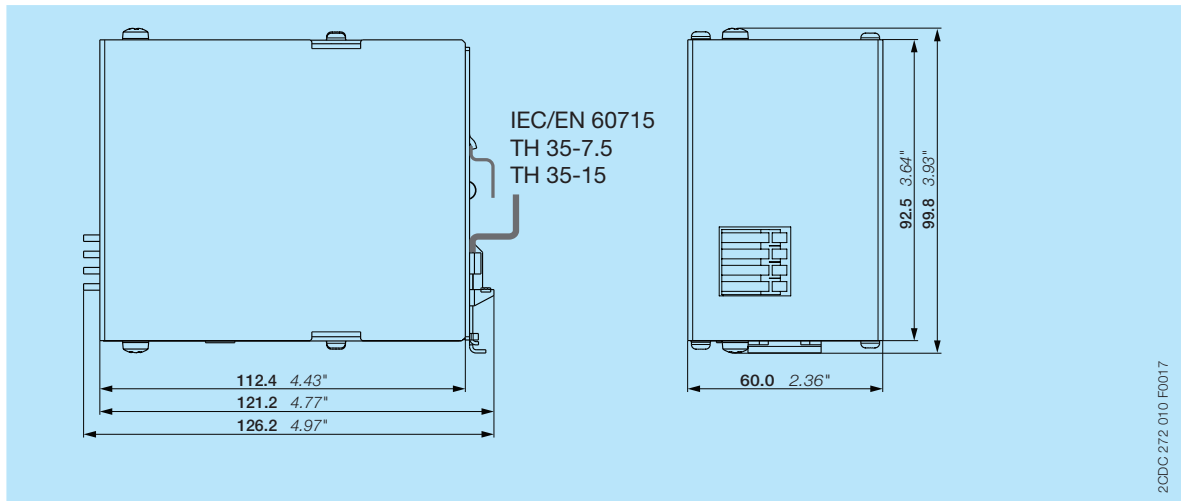

Accessory CP-B EXT.2